



FABRIC CUTTING MACHINE NTH-100

Key features:

- The NTH-100 round knife cutting machine has been designed for cutting any textile materials (from light to heavy depending on the version of the cutting machine).
- It can cut both low plies of fabric (even 2 layers) or cut high plies of materials.
- The Cutting machines NTH-100 have built in sharpeners designed for blade sharpening during operation.
- The cutting machines have blade height adjustment mechanism which allows to extend the life of the blade.
- Our round knife cutting machines are equipped with a universal single-phase commutator motor KASO 74/35 made in Poland.

Available versions of NTH-100 cutting machines:

NTH-100**W** high speed 1000 rpm version designed for lightweight materials.

NTH-100**N** low speed 500 rpm version designed for cutting hard materials (carpets, denim, felt etc.).

NTH-100**R** version with variable speed control in the range from 500 rpm to 1000 rpm.

Specifications:

Model: NTH-100

Blade diameter: 98 mm

Maximum cutting height: 85 mm

Voltage: 1 ~ 230 V / 50 Hz

Motor power: 380 W

Weight: 3.5 kg

Made in Poland.

+48 697 530 240
+48 61 876 89 46
info@rexelpoland.com



Scan the code



NTH-100N



NTH-100R



NTH-100W



NTH-100W
NTH-100N

NTH-100R

płynna regulacja obrotów ostrza
variable speed control of the blade
плавная регулировка вращения лезвия

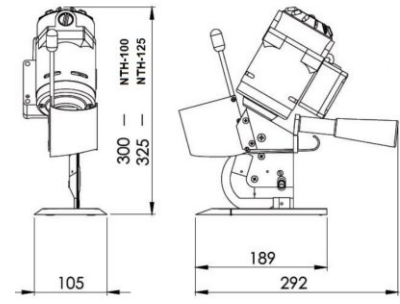

NTH-125 / NTH-100