



# FABRIC REWINDING AND CUT-TO-LENGTH MACHINE CTRLR-2000 KC

## Key features:

- The machine is designed to cut exact length and winds fabric onto a core.
- Works best with thick materials (blankets, rug-like materials, bedspreads).
- The machine consists of an unwinding belt cradle, "V" shaped belt conveyors, driven by an induction motor and the winding part. The winding module is made of four rubberized rollers 96mm in diameter, arranged in the shape of an arc with a diameter of 700mm. These two modules are driven by an induction motor. Additionally, the entire winding module is mounted on a geared transverse guide, which makes it possible to rewind material with edge alignment.
- After exact length is measured the automatic rolls stop and knife cuts through fabric.
- Machine can be produced with different specifications.
- The control panel is installed on swivel arm ensuring easy operation.
- The control panel is equipped with a high-quality touchscreen.
- Friendly user interface is available in Polish, English and Russian (other languages on request).

## Specifications:

Max roll width: 2000 mm  
Max roll diameter: 700 mm  
Max roll weight: 80 kg  
Overall dimensions (LxWxH): 3827x2147x1703 mm  $\pm$  30 mm  
Voltage: 230 V AC  
Power: 1.2 kW

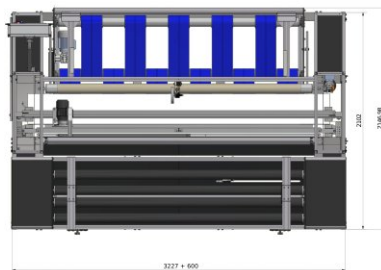
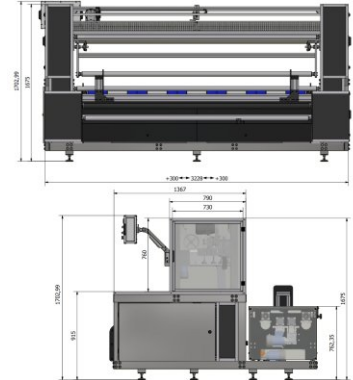

+48 697 530 240  
+48 61 876 89 46  
info@rexelpoland.com



Scan the code